

## ISM-167

### Singleboardcomputer with High Performance 16 Bit Microcontroller SAB-C167CR (Infineon)



The ISM-167 offers a capable 16 Bit microcontroller of type SAB-C167CR together with a Flash- und RAM-storage enlargement, a serial FRAM and a real time clock in a compact and consistent format of our ISM-family.

This module lend itself for applications with high standards on computing power and memory requirement. The C167 controller shows a minimal cycle time of 100 ns, and the ISM-167 is able to accept RAM-storage up to 512 KByte Flash and 1 MByte onboard.

The CPU already comprehends numerous peripheral components, like analog-digital-transformer, PWM-generators, SPI-bus, UART and a CAN-controller conformable to CAN 2.0B.

An integrated buscontroller with programmable CS-conductors, waitstates and many other adjusting possibilities, allows a trouble-free connection of external periphery without extra hardware.

The serial FRAM with 8 KByte storage is according to a serial EEPROM, and the advantage over the EEPROM is, that it owns a boundless write cycle number. Also, there is no writing deceleration on this type, which normally amounts to 1-10 ms per byte by the serial EEPROM's. Thus this storage can be introduced more flexible as an EEPROM. The both 68-pined connectors at the 1,27 mm raster present a good compromise between high packing density and sufficient robustness. The SMC-conneters

from ERNI are available for the variedly high counterparts. For this reason the distance to a carrier circuit board can be variegated.

#### Spezifications

- SAB-C167CR-LM CPU of Infineon
- Flash: 512 KByte Flash (8 Bit data bus)
- RAM: 1 MByte (16 Bit data bus)
- RTC: RTC8583 (I<sup>2</sup>C-bus)
- Serial FRAM: 8 KByte
- RS-232 interface transformer onboard
- highpole and robust Modulconnector (1,27 mm raster)
- extendable by processorbus (16 Bit data bus available), I<sup>2</sup>C-Bus and SPI-Interface
- measurement: 55 x 70 x 15 mm (l x w x h)
- current consumption: 80 mA

#### Options

- ISM-BASE-01
- Carrier circuit board with 9-36 V power supply, RS-232 Port and strips for different bus interfaces, JTAG connectors, user area

#### Order Informations

ISM-167                      with 1 MByte RAM

## Circuit Diagram ISM-167

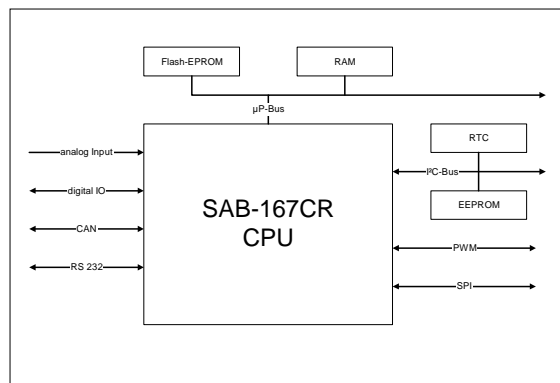

## Connectors

ST1		Pin No.	Pin No.	
	GND	a1	b1	D15
	D14	a2	b2	D13
	D12	a3	b3	D11
	D10	a4	b4	D9
	D8	a5	b5	D7
	D6	a6	b6	D5
	D4	a7	b7	D3
	D2	a8	b8	D1
	D0	a9	b9	GND
	A0	a10	b10	A1
	A2	a11	b11	A3
	A4	a12	b12	A5
	A6	a13	b13	A7
	A8	a14	b14	A9
	A10	a15	b15	A11
	A12	a16	b16	A13
	A14	a17	b17	A15
	A16	a18	b18	A17
	A18	a19	b19	A19
	GND	a20	b20	#WRL
	CLKOUT	a21	b21	#WRH
	#READY	a22	b22	#RD
	ALE	a23	b23	P215
	P214	a24	b24	P213
	P212	a25	b25	P211
	P210	a26	b26	P29
	P28	a27	b27	P77
	P76	a28	b28	P75
	P74	a29	b29	P67
	P66	a30	b30	P65
	#CS4	a31	b31	#CS3
	#CS2	a32	b32	#RTC-
	#RESET	a33	b33	#RSTO
	GND	a34	b34	VCC

ST2		Pin No.	Pin No.	
	P87	a1	b1	GND
	P86	a2	b2	P85
	GND Analog	a3	b3	SCKL
	P84	a4	b4	P83
	P82	a5	b5	P81
	TX-CANA	a6	b6	RX-CANA
	GND	a7	b7	P80
	P47 TX-CANB	a8	b8	P44 RX-CANB
	PWM3	a9	b9	PWM2
	PWM1	a10	b10	PWM0
	RXD0	a11	b11	TXD0
	STO	a12	b12	SRI
	P37	a13	b13	P36
	P35	a14	b14	P34
	P33	a15	b15	P32
	P31 (RXD1)	a16	b16	P30 (TXD1)
	PIN84	a17	b17	Vref
	P25	a18	b18	P24
	GND	a19	b19	P23 (HSHI)
	P22 (HSHO)	a20	b20	P21
	P20	a21	b21	P50
	P51	a22	b22	P52
	P53	a23	b23	P54
	P55	a24	b24	P56
	P57	a25	b25	P58
	P59	a26	b26	P510
	P511	a27	b27	P512
	P513	a28	b28	P514
	P515	a29	b29	PFI
	#PFO	a30	b30	WDI
	#WDO	a31	b31	SDA
	SCL	a32	b32	WP
		a33	b33	BATIN
	GND	a34	b34	VCC